

## Evaluation Report FLAMCO "Gooseneck Roof Vent" Roof Vent

### Manufacturer:

#### Florida Metal Products

6940 Stuart Avenue  
Jacksonville, FL 32254

*for*

### Florida Product Approval

#### # FL 21580.2 R2

Florida Building Code 7th Edition (2020)

Method: 2 - B

Category: Roofing

Sub - Category: Roofing Accessories that are an Integral  
Part of the Roofing System

Product Name: "Gooseneck Roof Vent"

Product Description: Roof Vent

Attached To: Wood Deck

### Prepared by:

James L. Buckner, P.E., SECB  
Florida Professional Engineer # 31242  
Florida Evaluation ANE ID: 1916  
Project Manager: Diana Galloway  
Report No. 20-244- GRV-ER  
(Revises 17-185-GRV-ER, FL 21580.2)  
Date: 09 / 25 / 20

This item has been electronically signed and sealed by James L. Buckner, P.E., on this date using a Digital Signature. Printed copies of this document are not considered signed and sealed, and the signature must be verified on any electronic copies.

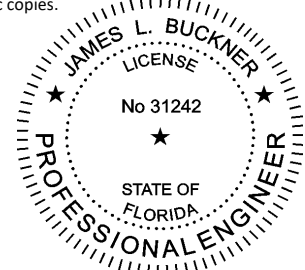

2020.09.25 14:33:30 -04'00'

### Contents:

Evaluation Report

Pages 1 – 9

- 1.0 Manufacturer:** Florida Metal Products dba FLAMCO  
6940 Stuart Avenue  
Jacksonville, Florida 32254  
(800) 634-8400  
<http://flamco.com>
- 2.0 Manufacturing Plant:** Jacksonville, Florida
- 3.0 Product:**
- 3.1 **Product Name:** "Gooseneck Roof Vent"  
3.2 **Product Description:** Roof Vent
- 4.0 Evaluation Scope:**
- 4.1 **Compliance with the following**  
Florida Building Code 7th Edition (2020)
- 4.2 **Evaluation Method:**  
Florida Product Approval Rule 61G20-3.005 (2) (b)
- 4.3 **Evaluation Classification:**  
Category: Roofing  
Sub Category: Roofing Accessories that are an Integral part of the Roofing System
- 4.4 **Properties Evaluated**  
Structural (Wind Resistance) Properties
- 4.5 **Limits of Evaluation:**  
This product assembly evaluation is limited to compliance with section 4.1 to section 4.4 of this report.
- 5.0 Evaluated Uses:**  
FLAMCO "Gooseneck Roof Vent" is used as a roof ventilator.
- 6.0 Product Assembly Description:**
- 6.1 **General:**  
The FLAMCO "Gooseneck Roof Vents" are gooseneck style roof vents for tile roofs fabricated from 26 gauge, G-90 primed, galvanized steel with a galvanized steel mesh covering mechanically attached to Plywood Deck.
- 7.0 General Assembly as Evaluated:**  
Refer to section 15.0 of this report for product assembly components/materials & standards.
- 8.0 Support System:**  
(Design of support system is outside the scope of this evaluation.)
- 8.1 Type: Wood Deck  
8.2 Description: 15/32" (min.) or greater plywood, or  
Wood plank deck (based on minimum density/specific gravity of 0.42)
- 9.0 Slope:**  
Minimum slope shall be 2:12. (and in compliance with FBC Chapter 15 based on the type of roof covering, applicable code sections and in accordance with manufacturer's recommendations.)

**10.0 Performance:**

## 10.1 Wind Resistance:

Table A Allowable Loads	
Design Uplift Pressure	-90 PSF

## Notes:

1. Allowable design pressure(s) for allowable stress design (ASD) with a margin of safety of 2 to 1.

**11.0 Performance Standard:**

The following test protocols were performed to demonstrate compliance with the intent of the code:

- 11.1 **ASTM E330-02** – *Standard Test Method for Structural Performance of Exterior Windows, Curtain Walls, and Doors and by Uniform Static Air Pressure Difference*

**12.0 Code Compliance:**

- 12.1 The product assembly described herein has demonstrated compliance with the Florida Building Code 7th Edition (2020) Section 1708.2.

**13.0 Limitations and Conditions of Use:**

- 13.1 Design of support system is outside the scope of this report. Support shall be structural framing members complying with the code and shall be designed by others.
- 13.2 Scope of "Limitations and Conditions of Use" for this evaluation:  
This evaluation report for "State Approval" contains technical documentation, specifications and installation method(s) which include "Limitations and Conditions of Use" throughout the report in accordance with Rule 61G20-3.005. Per Rule 61G20-3.004, the Florida Building Commission is the authority to approve products under "State Approval".
- 13.3 Option for application outside "Limitations and Conditions of Use"  
Rule 61G20-3.005(1)(e) allows engineering analysis for "project specific approval by the local authorities having jurisdiction in accordance with the alternate methods and materials authorized in the Code". Any modification of the product as evaluated in this report and approved by the Florida Building Commission is outside the scope of this evaluation and will be the responsibility of others.
- 13.4 This report is a building code product evaluation per FLPE rule (FAC) 61G15-36 to comply with Florida product approval rule (FAC) 61G20-3. This evaluation report is part of the Florida Building Commission approval for the listed code related criteria. This report by James Buckner, P.E. and CBUCK Engineering is not a design certification of code compliance construction submittal documentation, per FBC section 107, for any individual structure, site specific or permit design.
- 13.5 Structural loads shall comply with the design provisions of the FBC 7th Edition (2020), Chapter 16, Section 1609.
- 13.6 All metal components and fasteners shall be corrosion resistant in accordance with FBC, including but limited to Sections 1504.3.2, 1506.6 and 1507.4.4.
- 13.7 Refer to applicable building code section for ventilation requirements.
- 13.8 Fire Classification is outside the scope of Rule 61G20-3, and is therefore not included in this evaluation.
- 13.9 This report does not evaluate the use of this product assembly as described in this report for use in the High Velocity Hurricane Zone code section. (Dade & Broward Counties)

**14.0 Quality Assurance:**

The manufacturer has demonstrated compliance of products in accordance with the Florida Building Code and Rule 61G20-3.005 (3) for manufacturing under a quality assurance program audited by an approved quality assurance entity through Keystone Certifications, Inc., (FBC Organization #QUA ID:1824).

## 15.0 System/Components

### 15.1 "Gooseneck Roof Vent"

- 15.1.1 Material: Steel
- 15.1.2 Thickness: 26 gauge (min.)
- 15.1.3 Yield Strength: 40 ksi min.
- 15.1.4 Corrosion Resistance: In compliance with FBC Section 1507.4.3:  
ASTM A792 coated, or ASTM A653 G90 galvanized steel
- 15.1.5 Overall Product Dimensions (nominal):  
Refer to Table A on Page 5 of this report for product dimensions.
  - 15.1.5.1 Length(s): 4-1/2", 6-1/2" or 10-1/2" max.
  - 15.1.5.2 Width(s): 6-3/4", 7", or 10-1/4" max.
  - 15.1.5.3 Height(s): 6-1/8", 8-7/8", 13", 13-1/2" and 14-1/8" max.

### 15.2 Fastener:

- 15.2.1 Base Fastener: Attaches Roof Vent to Deck
  - 15.2.1.1 Type: Smooth or Ring Shank Roofing Nails
  - 15.2.1.2 Size: 11 gauge x 2" (Long)
  - 15.2.1.3 Corrosion Resistance: Per FBC Section 1506.5
  - 15.2.1.4 Standard: Per ASTM F 1667

### 15.3 Roof Adhesive:

- 15.3.1 Type: Standard Heavy bodied Flashing Cement
- 15.3.2 Description: Asbestos-free asphalt based roof cement
- 15.3.3 Application Size: 1/4" thick (min.)
- 15.3.4 Standard: Per ASTM D 4586 Type I

## 16.0 Installation Method:

(Refer to installation method at the end of this evaluation report.)

Prepare deck opening by trimming any shingles or tiles & existing nails that may interfere with ridge vent installation. Apply roof cement to the underside, back and side flanges of the ridge vent. Cement should be a 1/4" thick and extend 2" onto roof underlayment. (Install cement in compliance with manufacturer's installation guidelines.) Position vent base flange beneath loosened shingles and align with deck opening. Attach the unit side flanges to deck with fasteners per Section 15.2 spaced 4" o.c. and 1" from each end. Apply Roofing Cement to exposed fastener heads. Minimum fastener penetration thru bottom of support, 3/16".

The FLAMCO "Gooseneck Ridge Vent" shall be installed in compliance with the installation method listed in this report and applicable code sections of FBC 7th Edition (2020). The installation method described herein is in accordance with the scope of this evaluation report. Refer to manufacturer's installation instructions as a supplemental guide for attachment.

## 17.0 Evaluation Reference Data:

- 17.1 ASTM E330-02 Uniform Static Air Pressure Difference Test
  - By Fenestration Testing Laboratory, Inc. (FTL) (FBC Organization #TST ID: 1657)
  - Project #16-6647, Lab #9125, Dated: 11/09/16
- 17.2 Quality Assurance
  - By Keystone Certifications, Inc. (FBC Organization #: QUA 1824)
  - Licensee #440
- 17.3 Engineering Analysis
  - By James L. Buckner, P.E. @ CBUGK Engineering
  - (FBC Organization # ANE 1916)
- 17.4 Certification of Independence
  - By James L. Buckner, P.E. @ CBUGK Engineering
  - (FBC Organization # ANE 1916)

## Installation Method FLAMCO "Gooseneck Roof Vent"

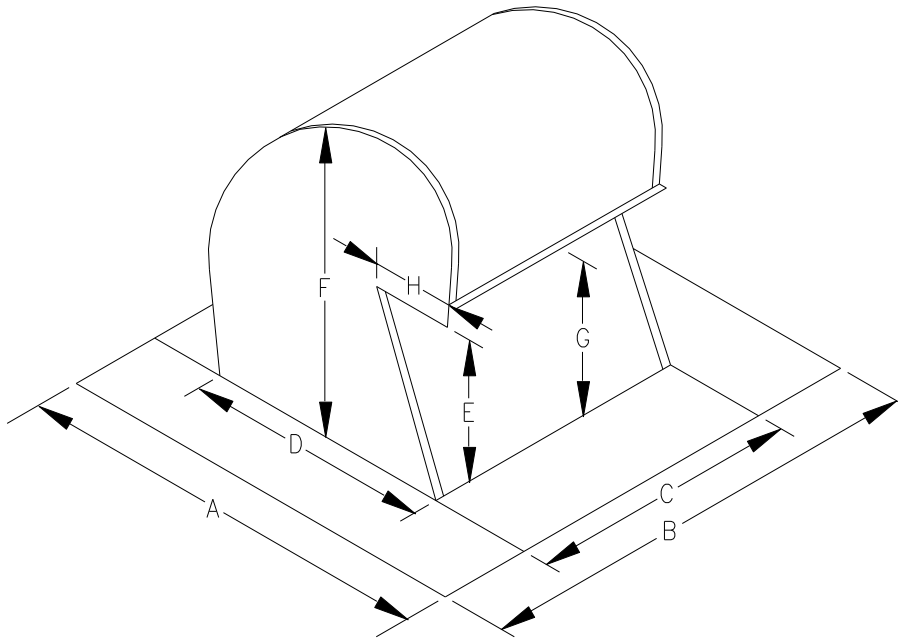

"Gooseneck Roof Vent"  
Typical Profile Isometric View

Dimensions	Pack	A	B	C	D	E	F	G	H
4" Short	24	11-3/4"	9-1/4"	4-1/2"	6-3/4"	3"	6-1/8"	4"	2-1/4"
4" Tile	10	12"	11-1/4"	4-1/2"	7"	10-1/4"	13-1/2"	10-1/2"	2-1/4"
6"	16	11-3/4"	11-1/4"	6-1/2"	6-3/4"	3"	6-1/8"	4"	2-1/4"
6" Tile	6	12"	11-1/4"	6-1/2"	7"	10-1/4"	13"	10-1/2"	2-1/4"
10"	6	15"	15-1/4"	10-1/2"	10-1/4"	4-3/4"	8-7/8"	5-1/8"	4"
10" Tile	4	15"	15-1/4"	10-1/2"	10-1/4"	10"	14-1/8"	11-1/8"	4"

TABLE A  
"Gooseneck Roof Vent"  
Dimensions